

Specification for Buzzer	Page	3/8
	Revision No.	1.0
	Drawing No.	OEM8124R
Model No. : KPI-G2312L-K8124		

## 1. 范围 Scope

This product specification is applied to the piezoelectric sounder in alarm systems. Please contact us when using this product for any other applications than described in the above.

本规格书适用于压电式蜂鸣器，通常它用在系统中做报警或提示的蜂鸣器用，如果将该产品用于其它领域，请与我们联系。

## 2. 概要 General

2.1 Out-Diameter : Ø23mm

外径: Ø23mm

2.2 Height : 19mm

高度: 19 mm

2.3 Weight : 8 gr.

重量: 8克

2.4 Case Material/Color : ABS/Black

壳体材质/颜色: ABS/黑

## 3. 额定极限条件 Maximum Rating

	项目 Item	规格 Specification
3.1	输入电压 input Voltage	7~12VDC
3.2	工作温度范围 Operating Temperature Range	-20 ~+60°C
3.3	储存温度范围 Storage Temperature Range	-30 ~+70°C

## 4. 电性能 Electrical Characteristics

	项目 Item	规格 Specification
4.1	声压 Sound Pressure Level	88dB at 9VDC/30cm
4.2	频率 Resonant Frequency	3.3± 0.5KHz
4.3	电流 Max.Rated Current	15mA at 9VDC
4.4	音调 Tone Nature	Continuous

测试条件参见下项

Refer to next item for measuring method.

Specification for Buzzer Model No. : KPI-G2312L-K8124	Page	4/8
	Revision No.	1.0
	Drawing No.	OEM8124R

## 5. 测试方法 Measuring Method

### 5.1 声压测试线路 S.P.L. Measuring Circuit

输入信号:9VDC  
Input Signal:9VDC

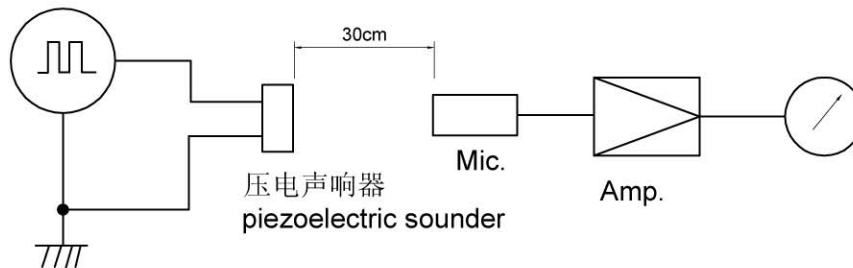

MIC : ND10 普通声级计或等同品  
MIC : ND10 Sound Meter or equivalent

稳压电源 : DF1730SL2A或等同品  
DC Power Supply : DF1730SL2A or equivalent

### 5.2 测试环境 Measuring Condition

温度 $+25 \pm 3^{\circ}\text{C}$ , 湿度 $60 \pm 10\% \text{R.H.}$ 标准测试状态,在没有疑问的场合,可以在温度 $+5 \sim +35^{\circ}\text{C}$ ,湿度 $45 \sim 85\% \text{R.H.}$ 的范围内测试.

Part shall be measured under a condition (Temperature : $+5$  to  $+35^{\circ}\text{C}$ , Humidity :45 to 85%R.H.) unless the standard condition (Temperature : $+25 \pm 3^{\circ}\text{C}$ , Humidity : $60 \pm 10\% \text{R.H.}$ ) is regulated measure.

## 6. 机械性能 Physical Characteristics

	实验项目 Item	实验条件 Test Condition	实验后规格 Specification
6.1	耐冲击性 Shock	峰值加速度 $490\text{m/s}^2$ , 半正弦波, XYZ三个方向各3次冲击实验后, 测试声响器. Sounder shall be measured after being applied shock( $490\text{m/s}^2$ ) for each three mutually perpendicular directions to each of 3 times by half sine wave.	符合表1的要求  The measured value shall meet Table 1.
6.2	耐振动性 Vibration Resistant	振动频率 $10 \sim 55 \text{ Hz}$ , $1.5\text{mm}$ 全振幅, XYZ三个方向各2小时试验后,测试声响器. Sounder shall be measured after being applied vibration of amplitude of $1.5\text{mm}$ with $10$ to $55\text{Hz}$ band of vibration frequency to each of 3 perpendicular directions for 2 hours.	

Specification for Buzzer	Page	5/8
	Revision No.	1.0
	Drawing No.	OEM8124R

Model No. : KPI-G2312L-K8124

## 7. 环境性能 Environmental Characteristics

	实验项目 Item	实验条件 Test Condition	实验后规格 Specification
7.1	高温放置 Dry Heat Test (Storage)	<p>放置于温度<math>+70\pm 2^{\circ}\text{C}</math>的烘箱内96小时, 然后取出, 在常温下放置4小时后, 测试声响器。</p> <p>After being placed in a chamber with <math>+70\pm 2^{\circ}\text{C}</math> for 96hours and then being placed in natural condition for 4 hours, sounder shall be measured.</p>	<p>符合表1的要求</p> <p>The measured value shall meet Table 1.</p>
7.2	低温放置 Cold Test (Storage)	<p>放置于温度<math>-30\pm 2^{\circ}\text{C}</math>的制冷箱内96小时, 然后取出, 在常温下放置4小时后, 测试声响器。</p> <p>After being placed in a chamber with <math>-30\pm 2^{\circ}\text{C}</math> for 96 hours and then being placed in natural condition for 4 hours, sounder shall be measured.</p>	
7.3	耐湿性 Humidity	<p>放置于 90%~95% R.H., 温度<math>+40\pm 2^{\circ}\text{C}</math>的环境试验箱内96小时, 然后取出, 在常温下放置4小时后, 测试声响器。</p> <p>After being placed in a chamber with 90 to 95%R.H. at <math>+40\pm 2^{\circ}\text{C}</math> for 96 hours and then being placed in natural condition for 4 hours, sounder shall be measured.</p>	
7.4	温度循环 Temperature Cycle	<p>先放置于温度<math>-30\pm 2^{\circ}\text{C}</math>的制冷箱内30分钟, 然后放置于室温(<math>+20^{\circ}\text{C}</math>)15分钟后, 放置于<math>+70\pm 2^{\circ}\text{C}</math>的烘箱内30分钟, 再放置于室温(<math>+20^{\circ}\text{C}</math>)15分钟。</p> <p>经过以上循环5次, 在常温下放置4小时后, 测试声响器。</p> <p>After being placed in a chamber at <math>-30\pm 2^{\circ}\text{C}</math> for 30 minutes, sounder shall be placed at room temperature(<math>+20^{\circ}\text{C}</math>). After 15 minutes at this temperature, sounder shall be placed in a chamber at <math>+70\pm 2^{\circ}\text{C}</math>. After 30 minutes at this temperature, sounder shall be returned to room temperature (<math>+20^{\circ}\text{C}</math>) for 15 minutes.</p> <p>After 5 above cycles, sounder shall be measured after being placed in natural condition for 4 hours.</p>	

表 1 Table 1

项 目 Item	试验后变化量 Specification after test
声压级 Sound Pressure Level	初始值 $\pm 10\text{dB}$ Initial Value $\pm 10\text{dB}$

Specification for Buzzer	Page	6/8
	Revision No.	1.0
Model No. : KPI-G2312L-K8124	Drawing No.	OEM8124R

### 8. Dimensions

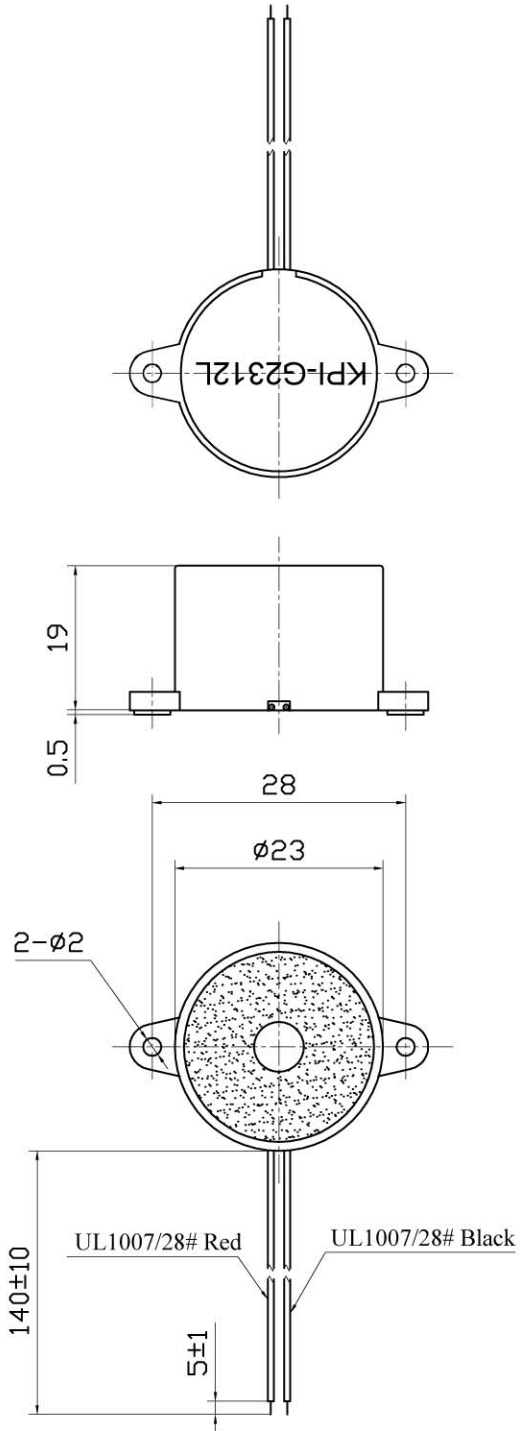

FIRST ANGLE PROJECTION



UNIT : mm  
Tolerance :  $\pm 0.5$